

# M262X840XE BLE 5.2 - LoRa M.2 Modules

Ver 1.00 Aug, 2021

M2 Series is available as a BLE 5.2 and LoRa combo module, or BLE only.

- BLE 5.2 module can be a Nordic nRF52840 with or without PA, or an nRF5340 module with or without PA.
- LoRa module uses a Semtech SX1262 with or without PA.
- The module is for an M.2 connector, B key.
- The most powerful BLE-LoRa combo module, M262XBT840XE with +20.99 dBm BLE TX power and +29.22 dBm LoRa TX power.
- M.2 pin outs are compatible with [LN60G840F](#) Series LTE-BLE module.

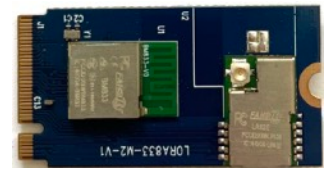

## Bluetooth Specifications

### BT840F/BT840XE Module with nRF52840

- Cortex M4F at 64 MHz, 1MB flash, 256 KB RAM.
- ARM® TrustZone® Cryptocell-310 co-processor
- BLE 5 data rate: 2Mbps, 1Mbps, 500kbps, 125kbps.
- IEEE 802.15.4 Thread and Zigbee data rate: 250 Kbps
- [BT840F](#) certified for BLE and 802.15.4
- Bluetooth range is 2300 meters at 125 Kbps for BT840F without PA.

- 8KB 2-way set associate cache
- ARM® TrustZone® Cryptocell-312 co-processor
- Network core:
  - 64 MHz Cortex M33 with 2KB instruction cache
  - 256KB flash, 64KB RAM
  - 2.6 mA in RX and 3.2 mA in 0dBm TX
  - Max. TX power is +3 dBm.

## LoRa Specifications

LoRa module is managed by BLE module on board.

- [LR62E](#), a Semtech SX1262 module.
- [LR62XE](#), SX1262 with SKY65313 PA.

## Application Examples

- [LEWR840XE6P](#): BLE-LoRa to LTE, WiFi, PoE Ethernet gateway.
- [SR840F6](#): BLE-LoRa sensor.

## Miscellaneous

- Operation temperature: -40°C to +85°C
- All necessary clock sources integrated
- Size: 30x42mm.
- Package: for M.2 connector, B Key, 67 pins.

## Hardware For Development

- EV board: EV-LN60G, M2 module not included.
- Nordic nRF52840DK or nRF5340DK

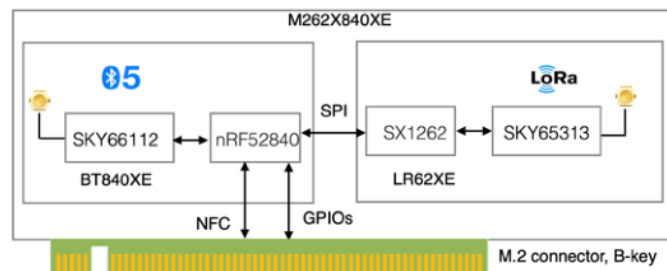

- [BT840XE](#) with SKY66112 PA, range >4500 meters.

### [BT40F](#) Module with nRF5340

- Dual core ARM® Cortex M33
- Application Core
- 128/64 MHz Cortex M33 with FPU and DSP instructions
- 1MB flash, 512KB RAM

## M262X840XE BLE-LoRa Modules

Module	M262840F	M262X40F	M262X840XE	M2840F	M240E	M2840XE
BLE module	BT840F	BT40F	BT840XE	BT840F	BT40E	BT840XE
BLE antenna	Integrated	Integrated	PA + u.FL	Integrated	u.FL	PA + u.FL
LoRa module	LR62E	LR62XE	LR62XE			
TX. BLE/LoRa	+8.49/+20.31dBm	+3.41/+29.22dBm	+20.99/+29.22dBm	+8.49 dBm	+3.41 dBm	+20.99dBm
Certifications	FCC,IC	FCC,IC	FCC,IC	FCC,IC,CE,RCM,TELEC	FCC,IC,CE,RCM,TELEC	FCC,IC,CE,RCM
QDID	108621	119517	108621	108621	119517	108621
Availability	Production	Non stock	Production	Non stock	Non stock	Non stock

## Table Of Contents

1. Introduction.....	3
M262X840XE Series, BLE-LoRa Combo Module .....	3
Available Bluetooth - LoRa Modules .....	4
Available Bluetooth Modules .....	4
2. Product Descriptions .....	5
BT840F .....	5
BT840XE .....	6
Mechanical Drawings .....	7
M.2 Connector Pin Assignments .....	9
Pin Function .....	11
3. Codes Development Using Nordic Tools.....	13
Over-The-Air DFU .....	13
SoftDevices .....	13
Development Tools .....	13
Control nRF21540 in BT40X .....	14
Control Skyworks Power Amplifier in BT840X.....	14
4. Application Examples .....	15
BLE-LoRa to LTE, WiFi, PoE Ethernet Gateway.....	15
5. EV-LN60G Evaluation Board.....	16
Nordic Development Tools.....	16
Programming Firmware into Evaluation Board.....	16
Android OS Apps .....	17
iOS Apps.....	17
EV-LN60G EvaluationBoard Schematics .....	18
6. Miscellaneous.....	20
Packaging and Lot Number .....	20
FCC Label .....	20
Revision History .....	21
Contact Us .....	22

## 1. Introduction

M262X840XE Series module has a Nordic nRF52840 or nRF5340 Bluetooth module. A Semtech SX1262 LoRa module with or without a power amplifier can be on board. The Bluetooth module manages the LoRa module and set up a connection to cloud server through Ethernet, WiFi, or LTE network connection.

This Series of module is referred as the **M2** module.

### M262X840XE Series, BLE-LoRa Combo Module

The following is a block diagram of M262X840XE. Module can be standalone, needing only DC power supply. Or, a host processor can control Bluetooth interface through M.2 connector pins.

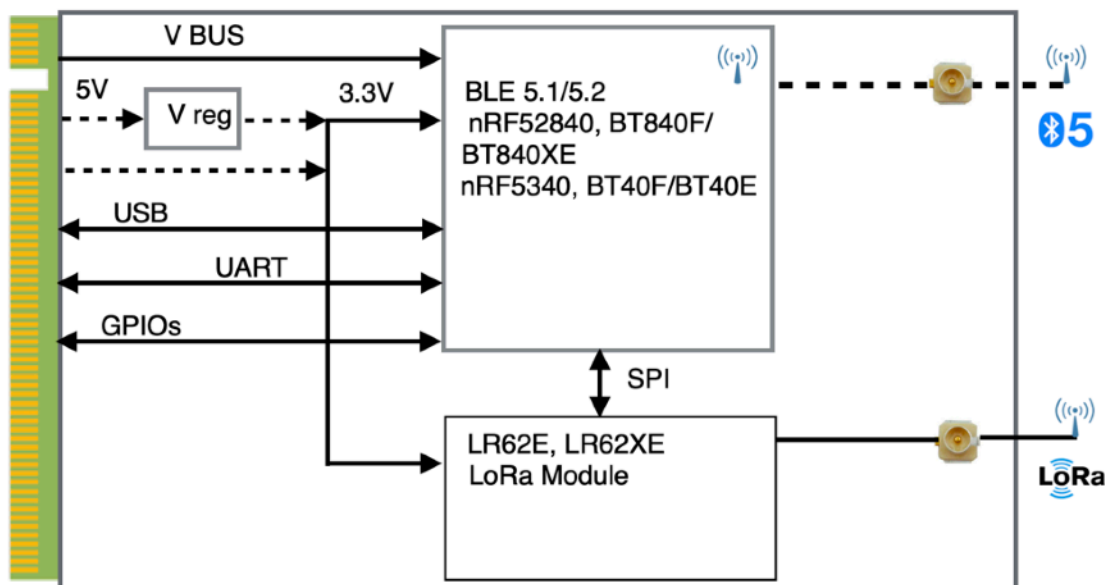

Modules available in the M262X840XE Series.

#### M262840F

- BT840F Bluetooth 5.2 module with Nordic nRF52840 and an integrated antenna.
- LR62E LoRa module with Semtech SX1262 and an u.FL connector for an external antenna.
- Size is 30x42mm, for M.2 connector, B key.

#### M262X40F

- BT40F Bluetooth 5.2 module with Nordic nRF5340.
- LR62XE LoRa module with Semtech SX1262, a power amplifier, and an u.FL connector for an external antenna.
- Size is 30x42mm, for M.2 connector, B key.

#### M262X840XE

- BT840XE Bluetooth 5.2 module with Nordic nRF52840, SKY66112 power amplifier, and an u.FL connector for an external antenna. FCC certified at +21 dBm TX power and with ANT000, a 0 dBi antenna.
- LR62XE LoRa module with Semtech SX1262, a power amplifier, and an u.FL connector for an external antenna.
- Size is 30x42mm, for M.2 connector, B key.

## M262X840XE BLE 5.2 - LoRa M.2 Modules

Ver 1.00 Aug. 2021

### M2840F

- BT840F Bluetooth 5.2 module with Nordic nRF52840 and an integrated antenna.
- Size is 30x42mm, for M.2 connector, B key.

### M240E

- BT40E Bluetooth 5.2 module with Nordic nRF5340 and an u.FL for an external antenna.
- Size is 30x42mm, for M.2 connector, B key.

### M2840XE

- BT840XE Bluetooth 5.2 module with Nordic nRF52840, SKY66112 power amplifier, and an u.FL connector for an external antenna. FCC certified at +21 dBm TX power and with ANT000, a 0 dBi antenna.
- Size is 30x42mm, for M.2 connector, B key.

## Available Bluetooth - LoRa Modules

M2 BLE-LoRa Modules	LoRa module	BLE module	M262X840XE High Power Series
M262840F	LR62E	BT840F	LoRa - BLE module
M262840E	LR62E	BT840E	LoRa-BLE module, u.FL
M262840X	LR62E	BT840X	LoRa-BLE+PA module
M262840XE	LR62E	BT840XE	LoRa-BLE+PA module, u.FL
M262X840F	LR62XE	BT840F	LoRa+PA-BLE module
M262X840E	LR62XE	BT840E	LoRa+PA-BLE module, u.FL
M262X840X	LR62XE	BT840X	LoRa+PA-BLE+PA module
M262X840XE	LR62XE	BT840XE	LoRa+PA-BLE+PA module, u.FL
M26240F	LR62E	BT40F	LoRa - BLE module
M26240E	LR62E	BT40E	LoRa-BLE module, u.FL
M262X40F	LR62XE	BT40F	LoRa+PA-BLE module
M262X40E	LR62XE	BT40E	LoRa+PA-BLE module, u.FL

## Available Bluetooth Modules

M2 BLE	BLE module
M2840F	BT840F
M2840E	BT840E
M2840X	BT840X
M2840XE	BT840XE
M240F	BT40F
M240E	BT40E

## 2. Product Descriptions

### BT840F

BT840F is a long range nRF52840 module. Product Specifications of nRF52840 can be downloaded from.

[https://infocenter.nordicsemi.com/index.jsp?topic=%2Fug\\_nrf91\\_dk%2FUG%2Fnrf91\\_DK%2Fintro.html&cp=2\\_0\\_2](https://infocenter.nordicsemi.com/index.jsp?topic=%2Fug_nrf91_dk%2FUG%2Fnrf91_DK%2Fintro.html&cp=2_0_2)

The following is a block diagram of Nordic nRF52840 Bluetooth Low Energy (BLE) SoC. Arrows with white heads indicate signals that share physical pins with other signals.

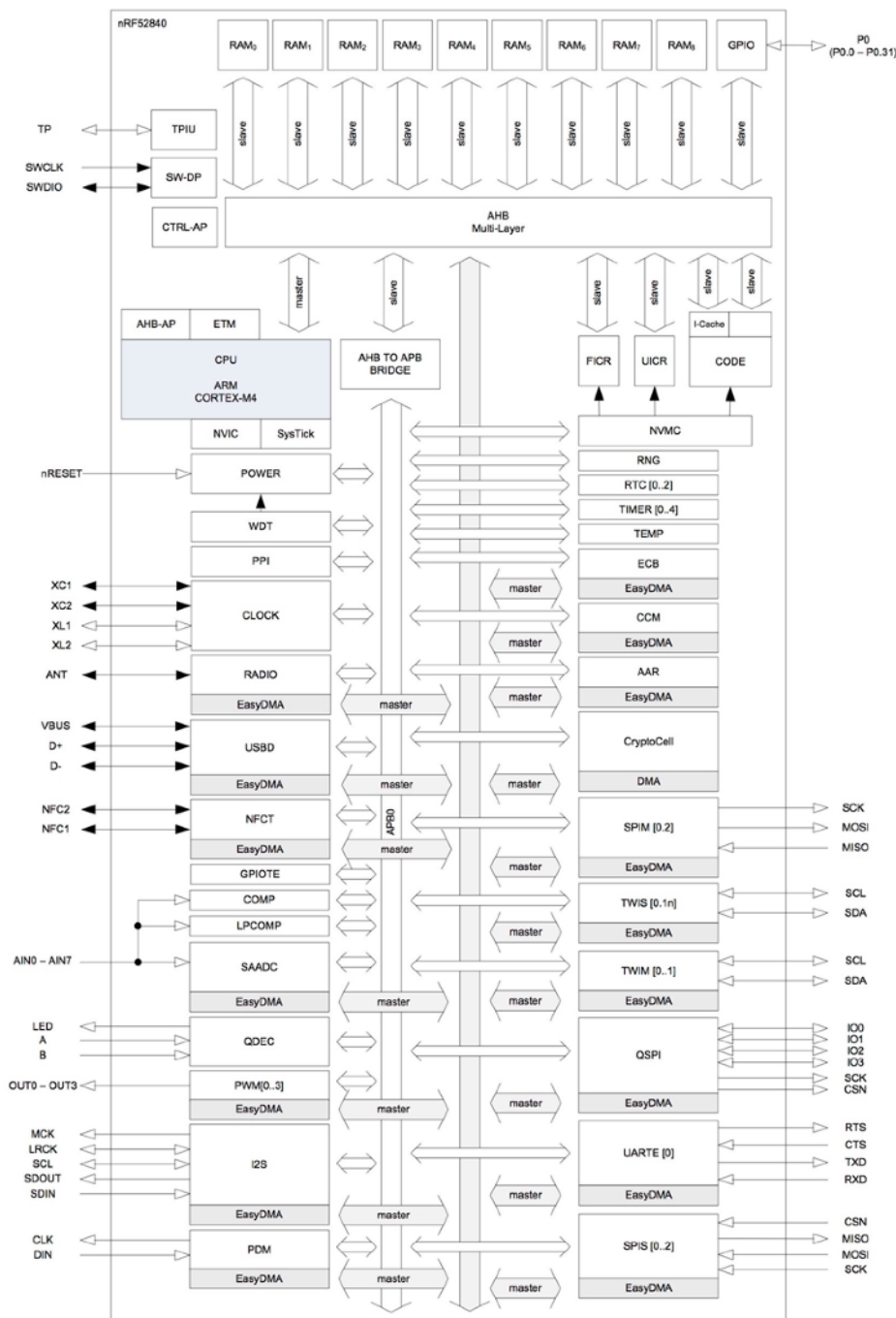

BT840F data sheets can be downloaded from:

<https://www.fanstel.com/download-document>

## BT840XE

A Skyworks power amplifier SKY66112 is integrated with nRF52840 in BT840X. A block diagram is shown below. nRf52840 codes to control SKY66112 are included in this data sheets. They can be downloaded from Fanstel webpage.

<https://www.fanstel.com/download-document>

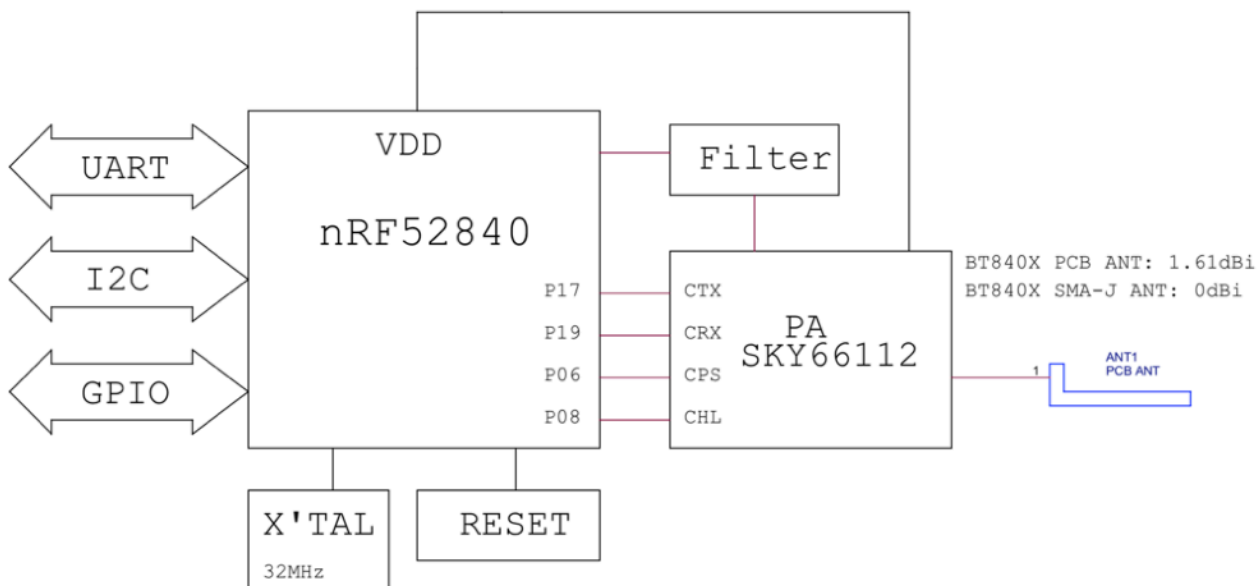

Frequency Band from 2402 MHz to 2480 MHz.

# M262X840XE BLE 5.2 - LoRa M.2 Modules

Ver 1.00 Aug. 2021

## Mechanical Drawings

Size of M262X840XE is 30x42mm.

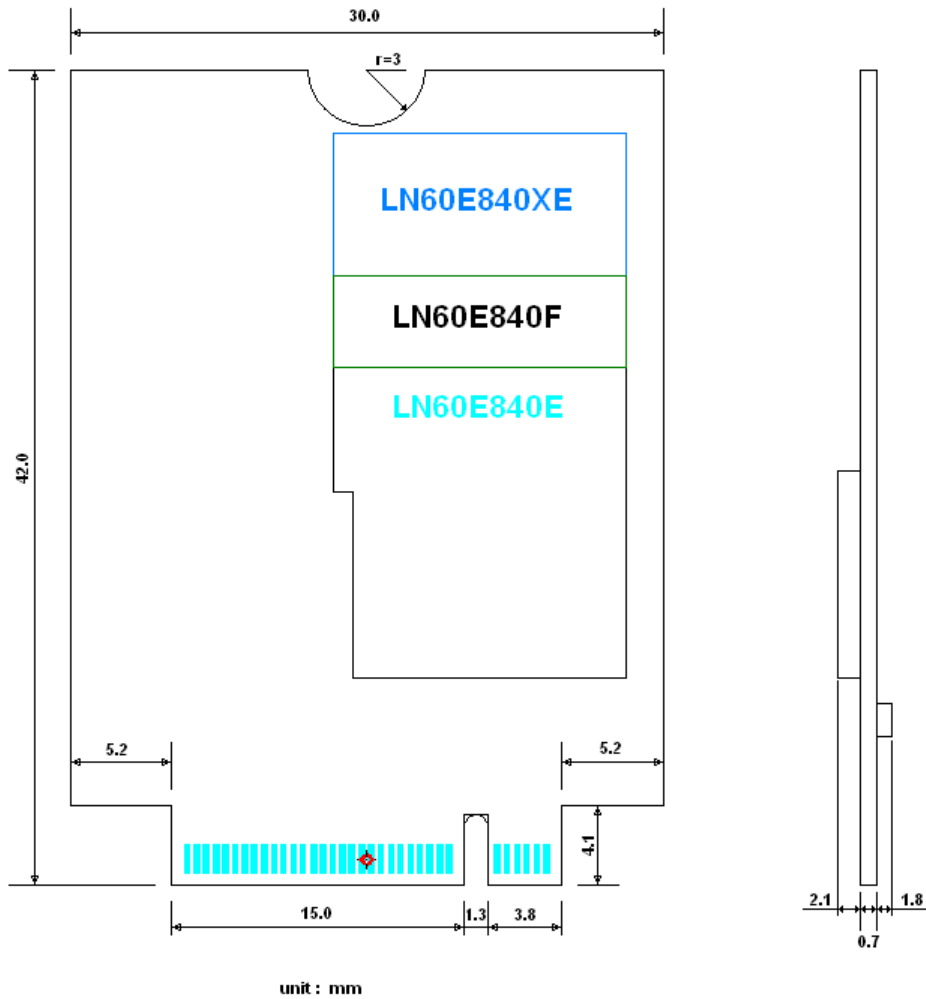

# M262X840XE BLE 5.2 - LoRa M.2 Modules

Ver 1.00 Aug. 2021

The following is detailed drawing of the M.2 connector.

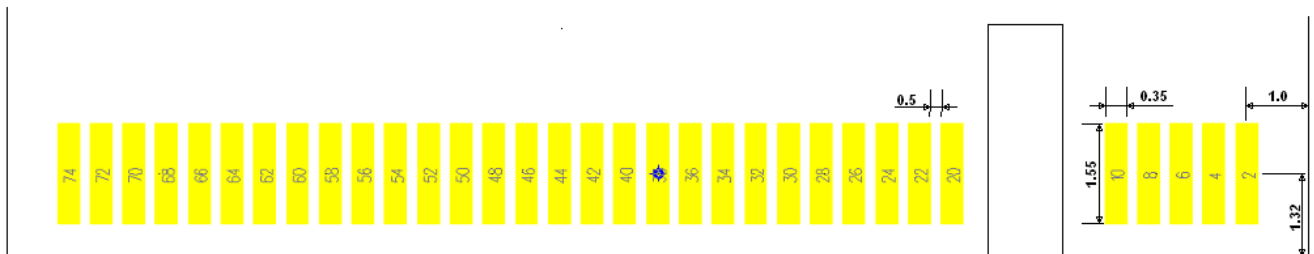
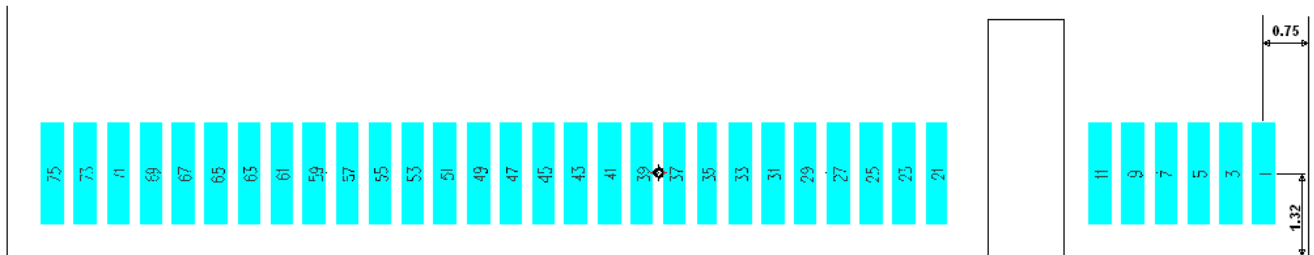

unit: mm



## M.2 Connector Pin Assignments

The followings are M262X840XE M.2 connector pin assignment. Pin functions are in a table in next section. Please refer to Nordic nRF5340, and nRF52840 Product Specifications for detailed descriptions and features supported. Pin names begin with BLE are Bluetooth module pins.

If you are working on a design accommodating both nRF52840 and nRF5340 modules,

- Blue color port names inside the rectangular are for nRF52840 modules.
- Green color port names outside the rectangular are for nRF5340 modules.
- Red color port names are for nRF9160 modules, pins are not used for this M262840XE Series module.

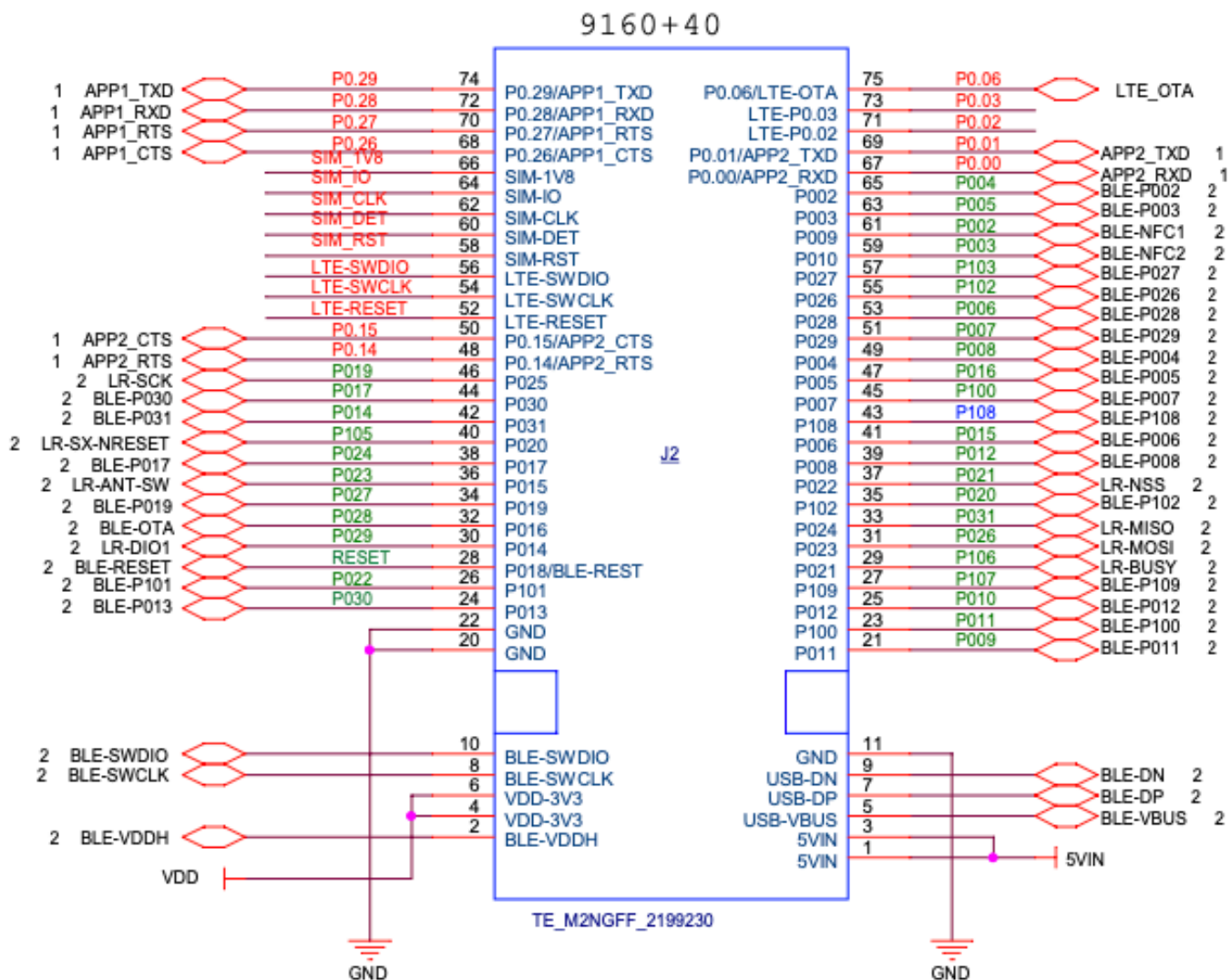

# M262X840XE BLE 5.2 - LoRa M.2 Modules

Ver 1.00 Aug. 2021

Pin assignments with nRF52840 module.

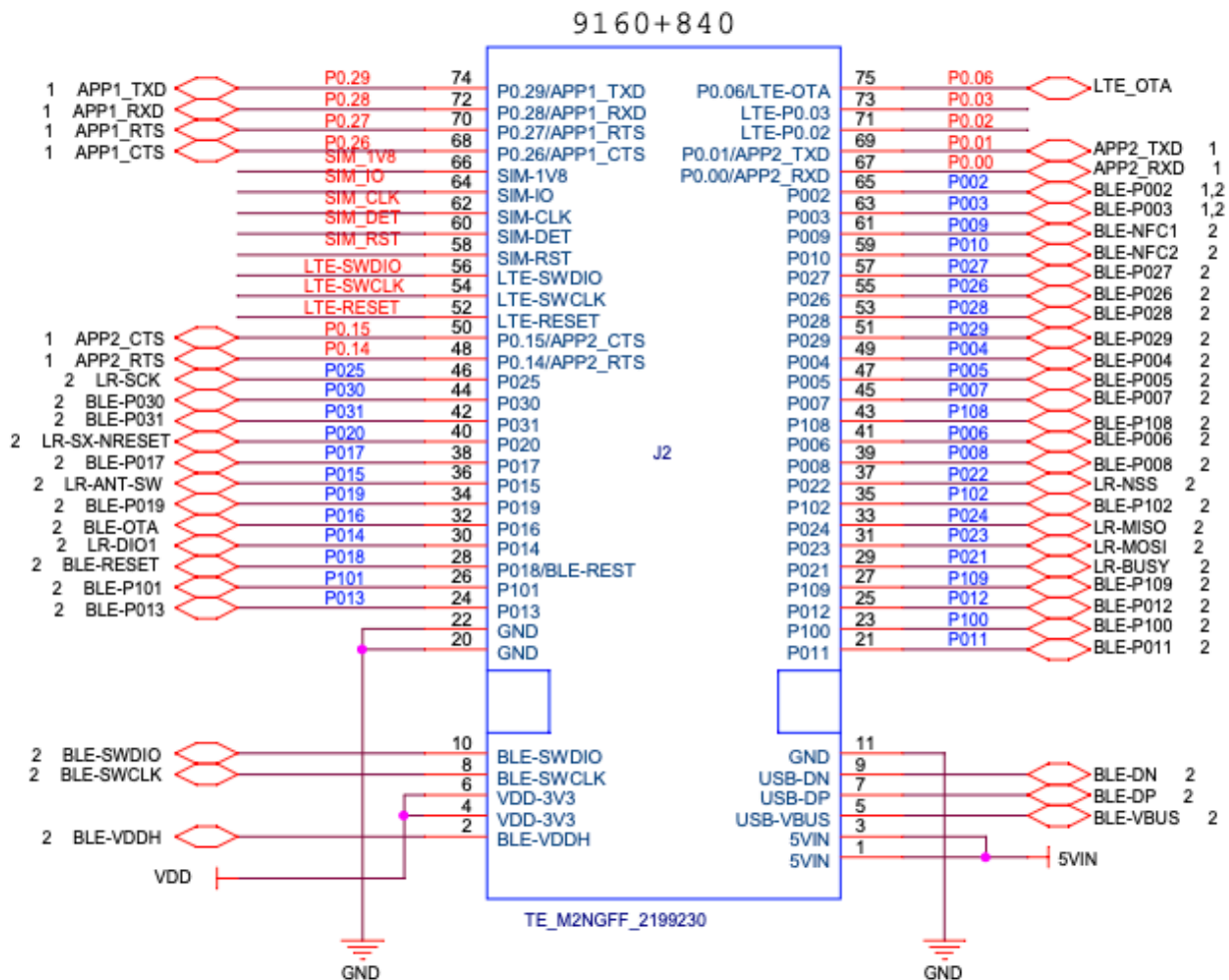

# M262X840XE BLE 5.2 - LoRa M.2 Modules

Ver 1.00 Aug. 2021

## Pin Function

M.2	9160	BT840F	BT840F/9160	BT40F	BT40F/9160	
pin#	pin#	pin#	Name	pin#	Name	Descriptions
1					5V IN	DC input for 3.3V regulator; 3.2V to 15V. 4.35V minimum if connected to USB-VBUS externally.
2		F4	BLE-VDDH	F4	BLE-VDDH	High voltage input for nRF52840/nRF5340, 2.5V to 5.5V
3					5V IN	DC input for 3.3V regulator; 3.2V to 15V. 4.35V minimum if connected to USB-VBUS externally.
4		9	VDD-3V3	9	VDD-3V3	Regulated 3.3V DC input, 800 mA minimum
5		F6	USB-VBUS	F6	USB-VBUS	USB power supply, 4.35V to 5.5V.
6		9	VDD-3V3	9	VDD-3V3	Regulated 3.3V DC input, 800 mA minimum
7		E4	USB DP	E4	USB DP	USB data pin
8		15	BLE-SWDCLK	15	BLE-SWDCLK	Serial Wire Debug clock input for BLE
9		E5	USB DN	E5	USB DN	USB data pin
10		16	BLE-SWDIO	16	BLE-SWDIO	Serial Wire Debug data for BLE
11		10	GND	10	GND	Ground
12						
13						
14						
15						
16						
17						
18						
19						
20			GND		GND	Ground
21		11	P011	11	P009	BLE GPIO
22			GND		GND	Ground
23		12	P100	12	P011	BLE GPIO
24		13	P013	13	P030	BLE GPIO
25		E6	P012	E6	P010	BLE GPIO
26		D5	P101	D5	P022	BLE_UART RXD
27		E3	P109	E3	P107	BLE GPIO
28		14	P018/RESET	14	RESET	Reset for BT40F, Reset or P018 for BT840F
29		E2	P021	E2	P106	BLE GPIO
30		D4	P014	D4	P029	BLE GPIO
31		D1	P023	D1	P026	BLE GPIO
32		D3	P016	D3	P028	BLE-OTA
33		C1	P024	C1	P031	BLE GPIO
34		D2	P019	D2	P027	BLE GPIO
35		C5	P102	C5	P020	BLE_UART-TXD
36		C4	P015	C4	P023	BLE GPIO
37		C2	P022	C2	P021	BLE GPIO
38		C3	P017	C3	P024	BLE GPIO
39		B5	P008	B5	P012	BLE GPIO
40		E1	P020	E1	P105	BLE GPIO
41		B4	P006	B4	P015	BLE GPIO

## M262X840XE BLE 5.2 - LoRa M.2 Modules

Ver 1.00 Aug. 2021

42		B3	P031	B3	P014	BLE GPIO
43		A6	P108	A6	P108	BLE GPIO
44		B2	P030	B2	P017	BLE GPIO
45		A5	P007	A5	P100	BLE GPIO
46		B1	P025	B1	P019	BLE GPIO
47		A4	P005	A4	P016	BLE GPIO
48	24		P0.14		P0.14	LTE_UART_APP2-RTS. No connect for M2 module.
49		A3	P004	A3	P008	BLE GPIO
50	25		P0.15		P0.15	LTE_UART_APP2-CTS. No connect for M2 module.
51		A2	P029	A2	P007	BLE GPIO
52	32		LTE-RESET		LTE-RESET	LTE reset, Active low. No connect for M2 module.
53		A1	P028	P006	P006	BLE GPIO
54	33		LTE-SWDCLK		LTE-SWDCLK	LTE-Single Wire Debug clock input. No Connect for M2 module.
55		1	P026	1	P102	BLE_I2C, SDA
56	34		LTE-SWDIO		LTE-SWDIO	LTE-Single Wire Debug data. No connect for M2 module.
57		2	P027	2	P103	BLE_I2C, SCL
58	43		SIM-RESET		SIM-RESET	LTE_SIM reset. No connect for M2 module.
59		8	P010	8	P003	BLE_GPIO, NFC2
60	45		SIM-DET		SIM-DET	LTE_SIM detect. No connect for M2 module.
61		7	P009	7	P002	BLE_GPIO, NFC1
62	46		SIM-CLK		SIM-CLK	LTE_SIM clock. No connect for M2 module.
63		6	P003	6	P005	BLE_GPIO, AIN1
64	48		SIM-IO		SIM-IO	LTE_SIM data. No connect for M2 module.
65		5	P002	5	P004	BLE_GPIO, AIN 0. No Connect for M2 module.
66	47		SIM-1V8		SIM-1V8	LTE_SIM 1.8V power supply. No connect for M.2 module.
67	95		P0.00		P0.00	LTE_UART_APP2-RXD. No connect for M2 module.
68	83		P0.26		P0.26	LTE_UART_APP1-CTS. No connect for M2 module.
69	96		P0.01		P0.01	LTE_UART_APP2_TXD. No connect for M2 module.
70	84		P0.27		P0.27	LTE_UART_APP1-RTS. No connect for M2 module.
71	97		P0.02		P0.02	LTE-GPIO. No connect for M2 module.
72	86		P0.28		P0.28	LTE_UART_APP1-RXD. No connect for M2 module.
73	99		P0.03		P0.03	LTE-GPIO. No connect for M2 module.
74	87		P0.29		P0.29	LTE_UART_APP1-TXD. No connect for M2 module.
75	3		P0.06		P0.06	LTE-OTA. No connect for M2 module.

### 3. Codes Development Using Nordic Tools

Development tools by Nordic and other third party development tools recommended by Nordic should be used.

Nordic development environment for nRF52840 offers a clean separation between application code development and embedded protocol stacks. This means compile, link and run time dependencies with the embedded stack and associated debugging challenges are removed. The Bluetooth low energy and ANT stack is a pre-compiled binary, leaving application code to be compiled stand-alone. The embedded stack interface uses an asynchronous and event driven model removing the need for RTOS frameworks.

#### Over-The-Air DFU

The nRF52840 is supported by an Over-The-Air Device Firmware Upgrade (OTA DFU) feature. This allows for in the field updates of application software and SoftDevice.

#### SoftDevices

The Nordic protocol stacks are known as SoftDevices and complement the nRF52 Series SoCs. All nRF52 Series are programmable with software stacks from Nordic. This bring maximum flexibility to application development and allows the latest stack version to be programmed into the SoC.

SoftDevices available from Nordic:

**S140:** Bluetooth low energy concurrent central/peripheral/observer/broadcaster stack.

#### Development Tools

Nordic Semiconductor provides a complete range of hardware and software development tools for the nRF52 Series devices. nRF52 DK board is recommended for firmware development.

Nordic software development tools can be downloaded from the following webpage.

[http://infocenter.nordicsemi.com/index.jsp?topic=/com.nordic.infocenter.nrf52/dita/nrf52/development/nrf52\\_dev\\_kit.html&cp=1\\_1](http://infocenter.nordicsemi.com/index.jsp?topic=/com.nordic.infocenter.nrf52/dita/nrf52/development/nrf52_dev_kit.html&cp=1_1)

### Control nRF21540 in BT40X

To be provided.

### Control Skyworks Power Amplifier in BT840X

BT840XE in M262X840XE uses SKYWORKS SKY66112-11 power amplifier.

A firmware example to control Skyworks SKY66112 power amplifier is below. This firmware file can be downloaded from <http://www.fanstel.com/download-document/>. Additional instructions for controlling SKY66112 are in BT840F Product Specifications, downloadable from the same web page.

Settings for BT840F and BT840E to pass certification testing.

- nRF52840 SoC TX power is set to +8dBm for FCC, ISED, CE, RCM, and TELEC certification testings.
- BT840E passes FCC and ISED certification testings with ANT060, a 6 dBi antenna.
- BT840E passes CE, RCM, and TELEC certification testings with ANT000 antenna.
- VDD is set to 3.3V with DCDC converter enabled.

Settings for BT840X and BT840XE to pass certification testing.

- nRF52840 SoC TX is set to +2dBm for FCC and ISED testings.
- nRF52840 SoC TX is set to -4 dBm for CE and RCM testings.
- BT840XE passes FCC, ISED, CE, and RCM certification testings with ANT000, a 0dBi antenna.
- VDD is set to 3.3V.

## 4. Application Examples

### BLE-LoRa to LTE, WiFi, PoE Ethernet Gateway

This application example supports multiple network interfaces and multiple protocols.

- PoE Ethernet and 802.11 b/g/n WiFi circuitry is on gateway host board.
- M.2 connectors for LTE/NB-IoT network expansion and to support Bluetooth, Thread, Zigbee, LoRa device interfaces.
- Data from sensors and other devices can be processed in the host board MCU (ESP32) before sending to cloud server.

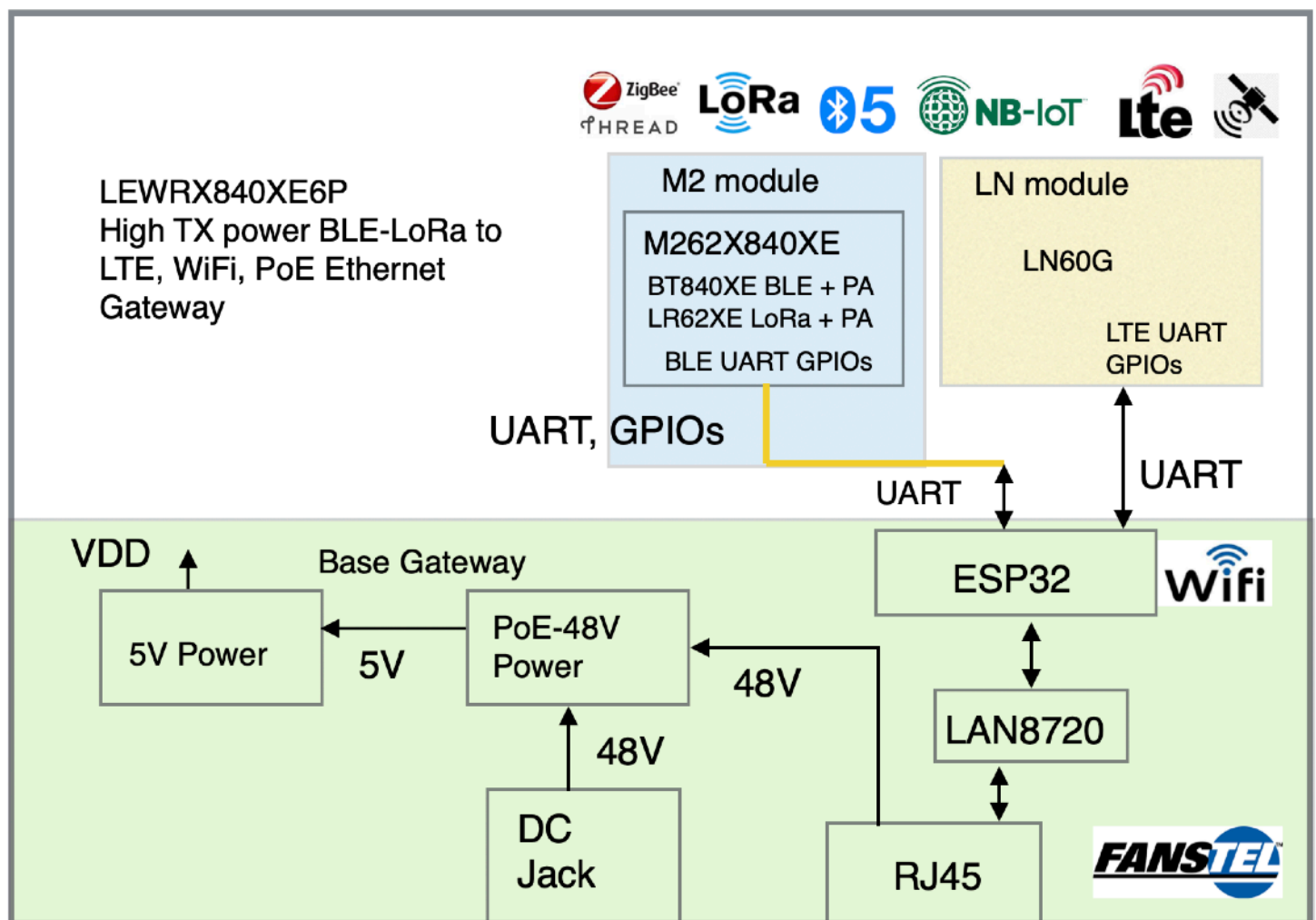

### 5. EV-LN60G Evaluation Board

An evaluation board can be used to evaluate performance of module and to develop and test your firmware before an application-specific host board is developed. An EV-LN60G include the followings:

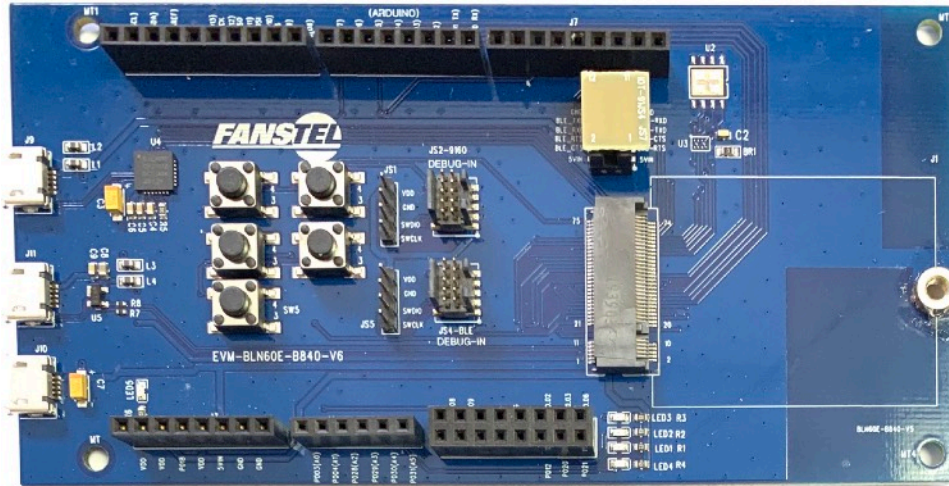

- An EV board without an M.2 module.
- A 10-pins flat cable.
- An USB cable

Additional hardware required but not included in EV-LN60G.

- An M2 module and an external antenna if required.

### Nordic Development Tools

A Nordic nRF52 DK is recommended for programming this evaluation board. Nordic development tools can be downloaded from:

<https://www.nordicsemi.com/eng/Products/nRF52840>

Many application examples can be downloaded from Nordic website.

Some firmware, Android OS, and iOS app codes can be downloaded from **Bluetooth 5 Codes** section of this Fanstel webpage.

<http://www.fanstel.com/download-document/>

### Programming Firmware into Evaluation Board

Download and set up basic software tools for programming.

nRF command line tool 10.2.1 or newer.

<https://www.nordicsemi.com/Software-and-Tools/Development-Tools/nRF-Command-Line-Tools/Download>

nRF Connect desktop 3.2.0 or newer.

<https://www.nordicsemi.com/Software-and-Tools/Development-Tools/nRF-Connect-for-desktop>



## M262X840XE BLE 5.2 - LoRa M.2 Modules

Ver 1.00 Aug. 2021

To program an nRF52840 module BLE module.

- Connect Nordic nRF52840DK **debug out** to Fanstel evaluation board **debug in** using the 10-pin flat cable as shown below.

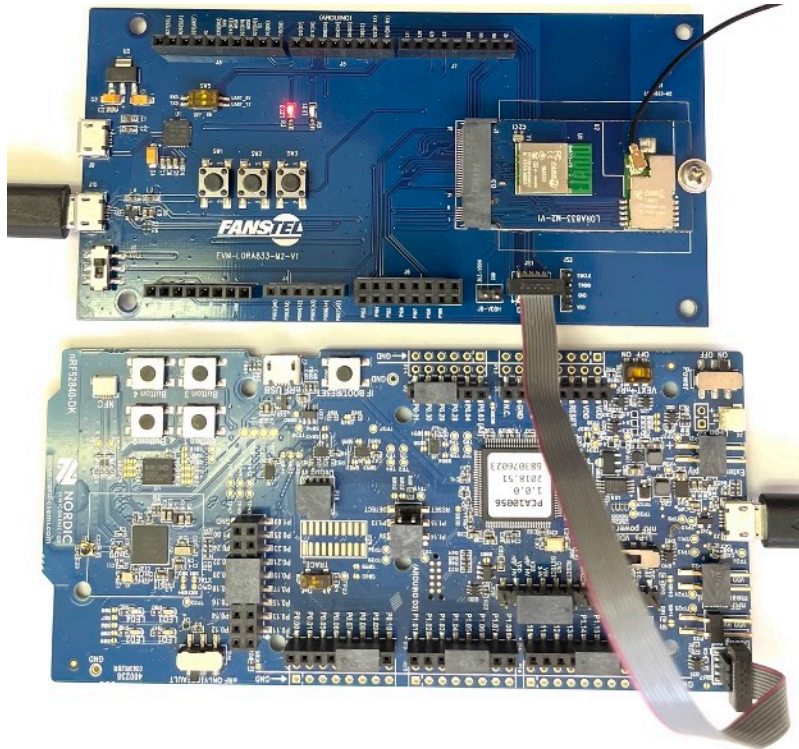

- Connect Nordic nRF52DK to PC.
- Connect a DC power source to micro or mini USB port of evaluation board.
- A Nordic nRF5340 DK board is required to program an nRF5340 module, e.g., BT40F.

### Android OS Apps

The following Android OS apps are available for download from Google Play Store:

**BlueNor nrf5x:** to use with Bluetooth 5 stacks, AT commands, or Slave firmware. Master firmware does not connect to a smartphone. Source codes can be downloaded from <http://www.fanstel.com/download-document/>

**BlueNor Mesh:** to use with BlueNor mesh firmware to send command to any node in a mesh. Node number is displayed when acknowledgement is received. Source codes will be uploaded to Fanstel website when supporting Bluetooth 5.

### iOS Apps

The following iOS apps can be downloaded from Apple APP Store.

**BlueNor Mesh:** to use with BlueNor mesh firmware to send command to any node in a mesh. Node number is displayed when acknowledgement is received.

**BlueNor nrf5x** firmware, apps, and source codes will be uploaded when ready.



# M262X840XE BLE 5.2 - LoRa M.2 Modules

Ver 1.00 Aug. 2021

Page 2 of EV-LN60G schematics. EV board schematics can be used as a reference design for using modules.

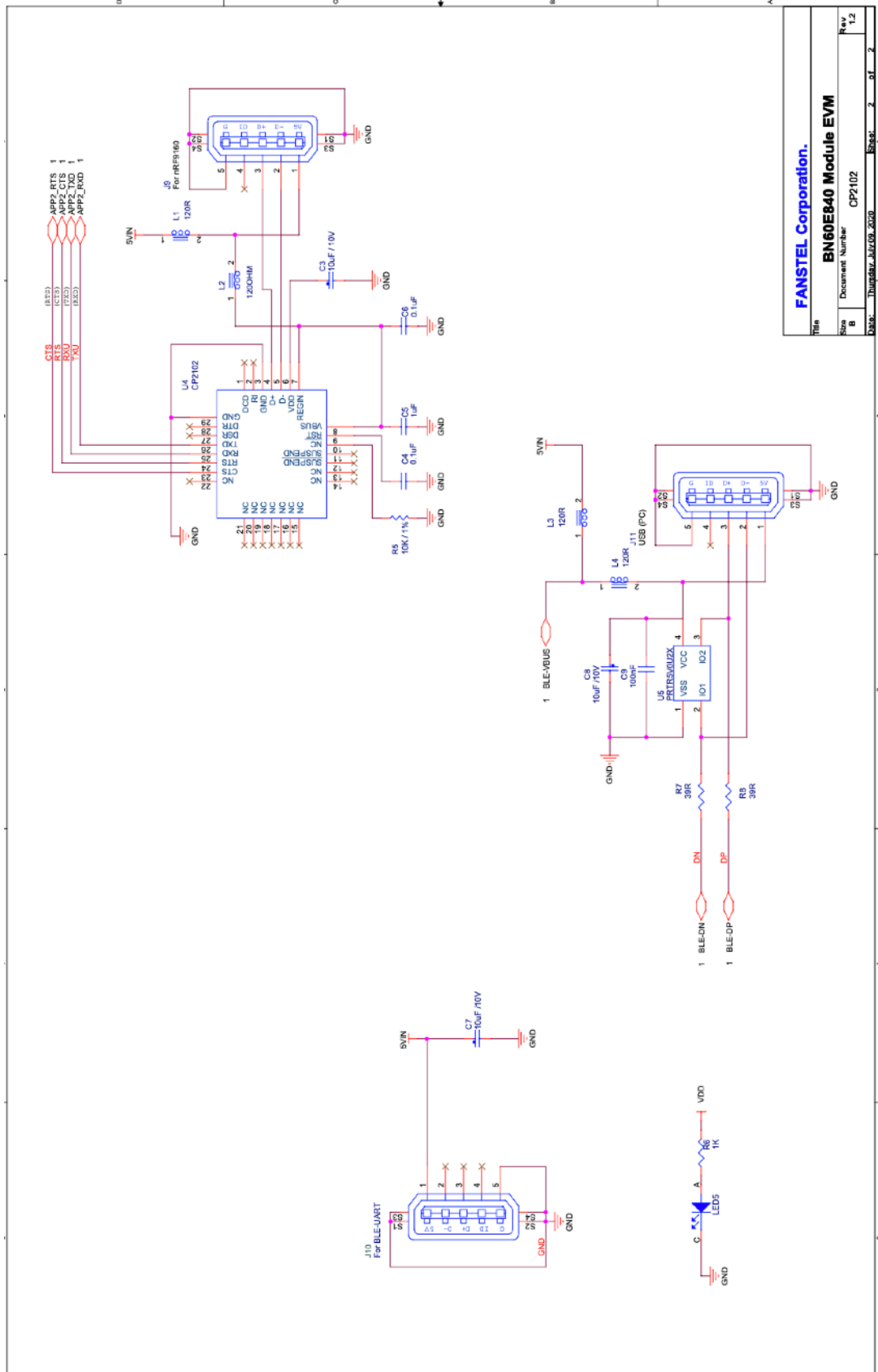

## 6. Miscellaneous

### Packaging and Lot Number

Production modules are delivered in reel, 1000 modules in each reel. Lot number for modules made after May 2019, can be used to track silicon version of SoC, module PCB version, and production test code version.

(K) Cust. PO:2630427

(4K) Cust. PO line:00003

(P) Cust. P/N : 1914-1019-2-ND

(1T) Lot :D0V218B-0000000

(Q) QTY :1000

(1P) MFG P/N : BT840F

(6D) Ship Date :20190522

(9D) Date : 1920

(4L) COO: CN

MSL	3/260°C
(E)	e4
<b>RoHS</b>	

### Lot: **D0 V2 18B - 00 00 000**

D0: 2 digits, version number of SoC.

V2: 2 digits, version number of module PCB.

18B: the first 2 digits for production test codes released year and the last digit for month in hex format. A=October, B=November, C=December. 18B was released in November 2018.

00 00 000, 7 digits, reserved for 2nd SoC for modules with 2 SoCs.

### FCC LABEL

The Original Equipment Manufacturer (OEM) must ensure that the OEM modular transmitter must be labeled with its own FCC ID number. This includes a clearly visible label on the outside of the final product enclosure that displays the contents shown below. If the FCC ID is not visible when the equipment is installed inside another device, then the outside of the device into which the equipment is installed must also display a label referring to the enclosed equipment

The end product with this module may subject to perform FCC part 15 unintentional emission test requirement and be properly authorized.

This device is intended for OEM integrator only.

### Revision History

- Aug. 2020, Ver. 0.60: Initial draft release
- Feb. 2021, Ver. 0.90: Draft update
- Aug. 2021, Ver. 1.00: Initial release

## Contact Us

### United States:

Fanstel Corp.

7466 E. Monte Cristo Ave. Scottsdale AZ 85260

Tel. 1 480-948-4928

Fax. 1-480-948-5459

Email: [info@fanstel.com](mailto:info@fanstel.com)

Website: [www.fanstel.com](http://www.fanstel.com)

### Taiwan:

Fanstel Corp.

10F-10, 79 Xintai Wu Road

Xizhu, New Taipei City, Taiwan 22101

泛世公司

臺灣省新北市汐止區新臺五路79號10樓之10, 22101

Tel. 886-2-2698-9328

Fax. 886-2-2698-4813

Email: [info@fanstel.com](mailto:info@fanstel.com)

Website: [www.fanstel.com](http://www.fanstel.com)

### China:

Fanstel Technologies Corp.

11 Jiale Street

Ping-Dih, Long-Gang, Shen Zhen, GD 518117

泛世康科技(深圳)有限公司

廣東省深圳市龍崗區坪地鎮佳樂街11號

Tel. 86-755-8409-0928

Fax. 86-755-8409-0973

QQ. 3076221086

Email: [info@fanstel.com](mailto:info@fanstel.com)

Website: [www.fanstel.com](http://www.fanstel.com)